

Sheave and sheave tracks are intended for underneath support of single, bi-parting and by-passing sliding doors. The three series (no. 14, no. 18, no. 20) cover the widest range of applications. The no. 20 series is recommended for store fixtures, case goods, wardrobe, kitchen cabinets and similar light duty doors. The no. 14 and no. 18 series are intended for medium and heavy duty residential and commercial installations.

Sheaves and sheave tracks require less headroom, eliminating top hung hardware, and are less conspicuous than overhead sliding door hardware. The no. 14 and no. 18 series have a self-lubricant nylon wheel for quiet, easy rolling; the no. 20 series offers a choice of nylon or metal wheel with self-lubricant oilite bushings for durability, abrasion and heat resistance. Accurate fitting of sheaves and sheave tracks minimize jumping.

Technical specifications vary.

See individual sheave and sheave track descriptions.

- Choice of wheel material
- Metal: long wearing, can't be nicked abrasion resistant, heat resistant
- Self-lubricating bronze oilite bushings on metal wheels. (nylon is self-lubricating)
- Accurate fitting of sheaves and tracks minimizes jumping
- All sheaves and tracks are available in rust resistant materials
- Simple installation to door and floor
- Made in USA

## Sheave 20

for  $\frac{3}{4}$ " min door thickness  
for 50 lbs. doors

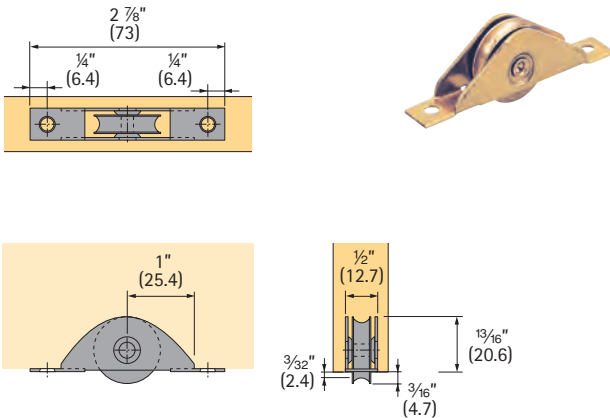

Finish	Order no.	PU
Wheel - brass, housing - brass	050 452	12
Wheel - nylon, housing - brass	050 453	12
Wheel - nylon, housing - steel	050 454	12
Wheel - brass, housing - steel	050 455	12

Screws included

## Track 20

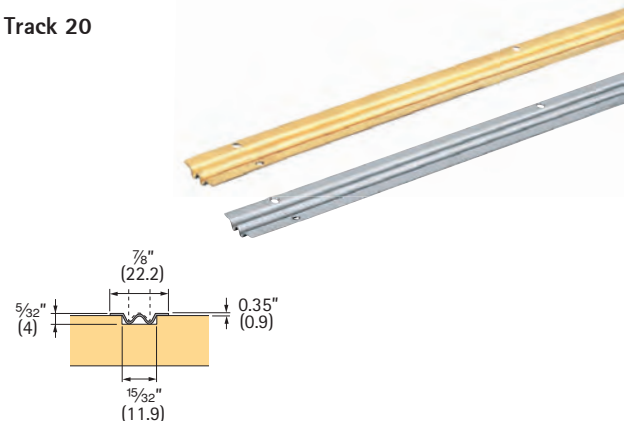

Article	Finish	Order no.	PU
6' (1800 mm)	brass	050 433	5
8' (2400 mm)	brass	050 434	5
10' (3000 mm)	brass	050 435	5
12' (3600 mm)	brass	050 436	5
10' (3000 mm)	stainless steel	050 440	5
12' (3600 mm)	stainless steel	050 441	5

Screws not included - recommend # 2 Flat Head

## Continuous floor guide 2014

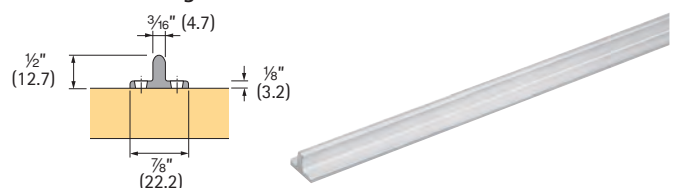

Length	Order no.	PU
6' (1800 mm)	050 448	5
8' (2400 mm)	050 449	5
10' (3000 mm)	050 450	5
12' (3600 mm)	050 451	5

Screws not included - recommend # 6 Flat Head

# Sheaves and Tracks

## Sheave 18

for 1" min door thickness  
for 125 lbs. doors

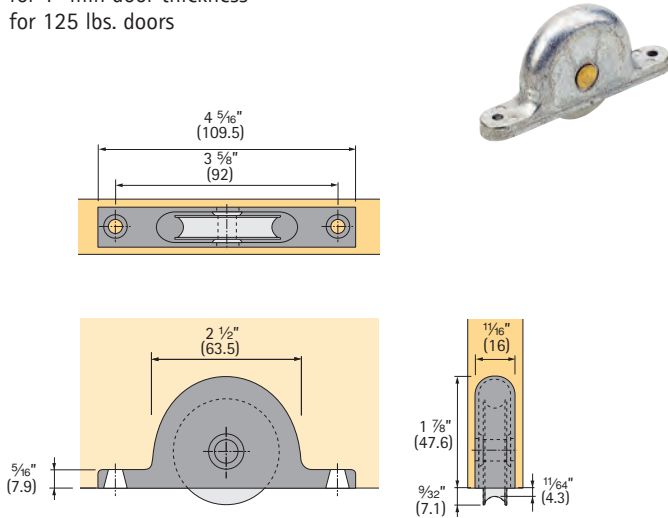

Article	Order no.	PU
Wheel - nylon, housing - zamac	050 432	12

Screws included

## Track 18

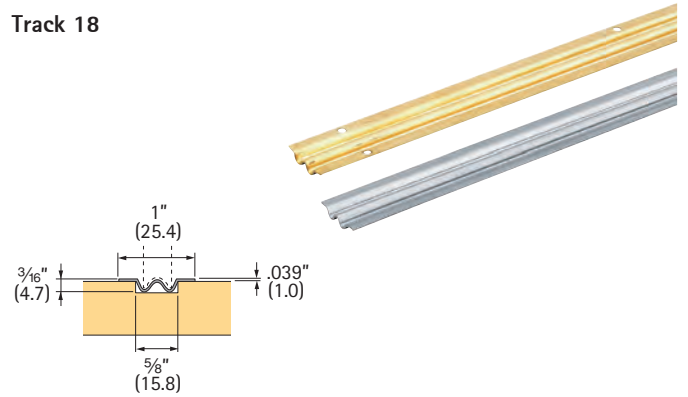

Article	Finish	Order no.	PU
6' (1800 mm)	brass	050 424	5
8' (2400 mm)	brass	050 425	5
12' (3600 mm)	brass	050 427	5
6' (1800 mm)	stainless steel	050 428	5
8' (2400 mm)	stainless steel	050 429	5
10' (3000 mm)	stainless steel	050 430	5
12' (3600 mm)	stainless steel	050 431	5

Screws not included - recommend # 2 Flat Head

## Sheave 14

for 1 1/4" min door thickness  
for 200 lbs. doors

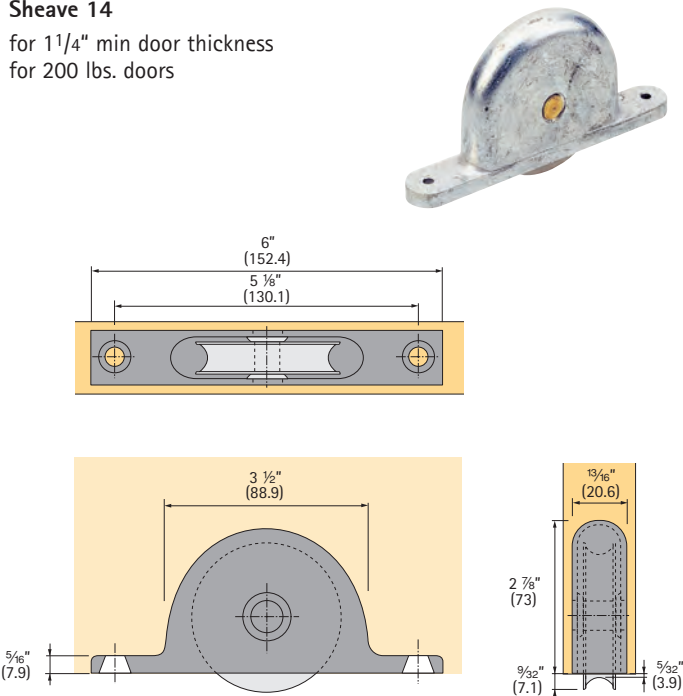

Article	Order no.	PU
Wheel - nylon, housing - zamac	050 179	12

Screws included

## Track 14

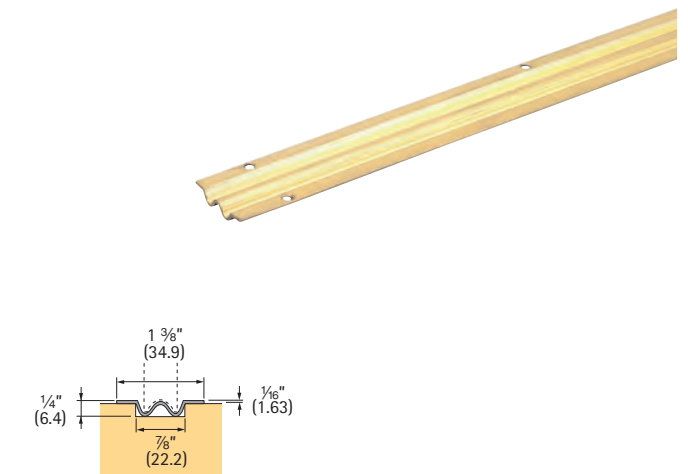

Length	Finish	Order no.	PU
6' (1800 mm)	bronze	050 175	5
8' (2400 mm)	bronze	050 176	5
10' (3000 mm)	bronze	050 177	5
12' (3600 mm)	bronze	050 178	5

Screws not included - recommend # 4 Flat Head