

Klassik D Flap stay with L 258 D support



Klassik D Flap stay with L 258 D support All metal

High-quality, maintenance-free
braking system with fine adjustment.

Guide bar, tie bar and base: nickel-plated steel

Housing and support: nickel-plated die-cast zinc

Order numbers refer to left-hand versions.
Use left or right by repositioning the base.

Article	Cabinet internal height mm	Order no.	PU
Klassik D/300	300 - 350	016 173	10
Klassik D/350	350 - 400	016 174	10
Klassik D/400	400 - 450	016 175	10
Klassik D/450	450 - 500	016 176	10
Klassik D/500	500 - 550	016 177	10
Klassik D/550	550 - 600	016 178	10

Assembly notes

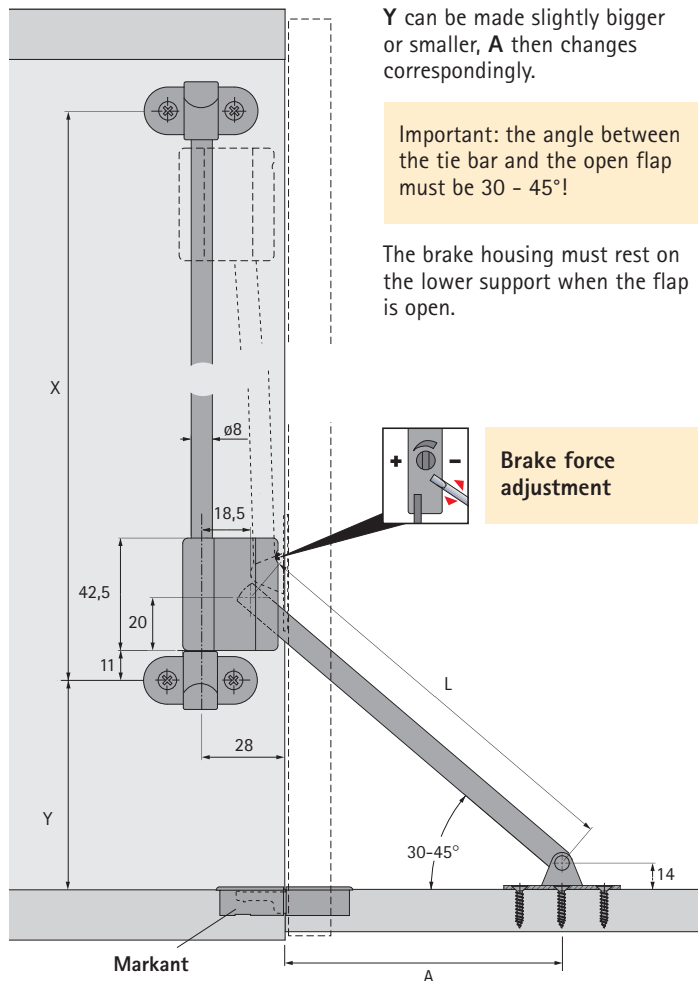

L 258 D support

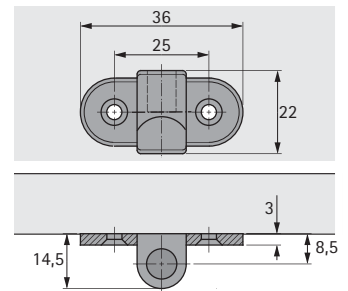

A 3 base

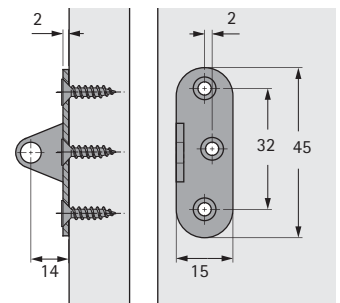

Fasten with \varnothing 3,5 DIN95 / DIN97 wood screws

Article	Cabinet internal height mm	Dimensions mm			
		X	Y	A	L
Klassik D/300	300 - 350	182	100	88	153
Klassik D/350	350 - 400	224	112	119	183
Klassik D/400	400 - 450	252	126	134	203
Klassik D/450	450 - 500	272	138	150	223
Klassik D/500	500 - 550	322	175	184	273
Klassik D/550	550 - 600	372	168	204	283