

Selekta Pro 2000

Fast assembly hinges for office
and commercial furniture



Selekta Pro 2000

The program

- opening angles 180° and 270°
- with pre-mounted pan-head screws
- with eccentric height adjustment ± 2 mm
- with eccentric overlay adjustment -2 mm

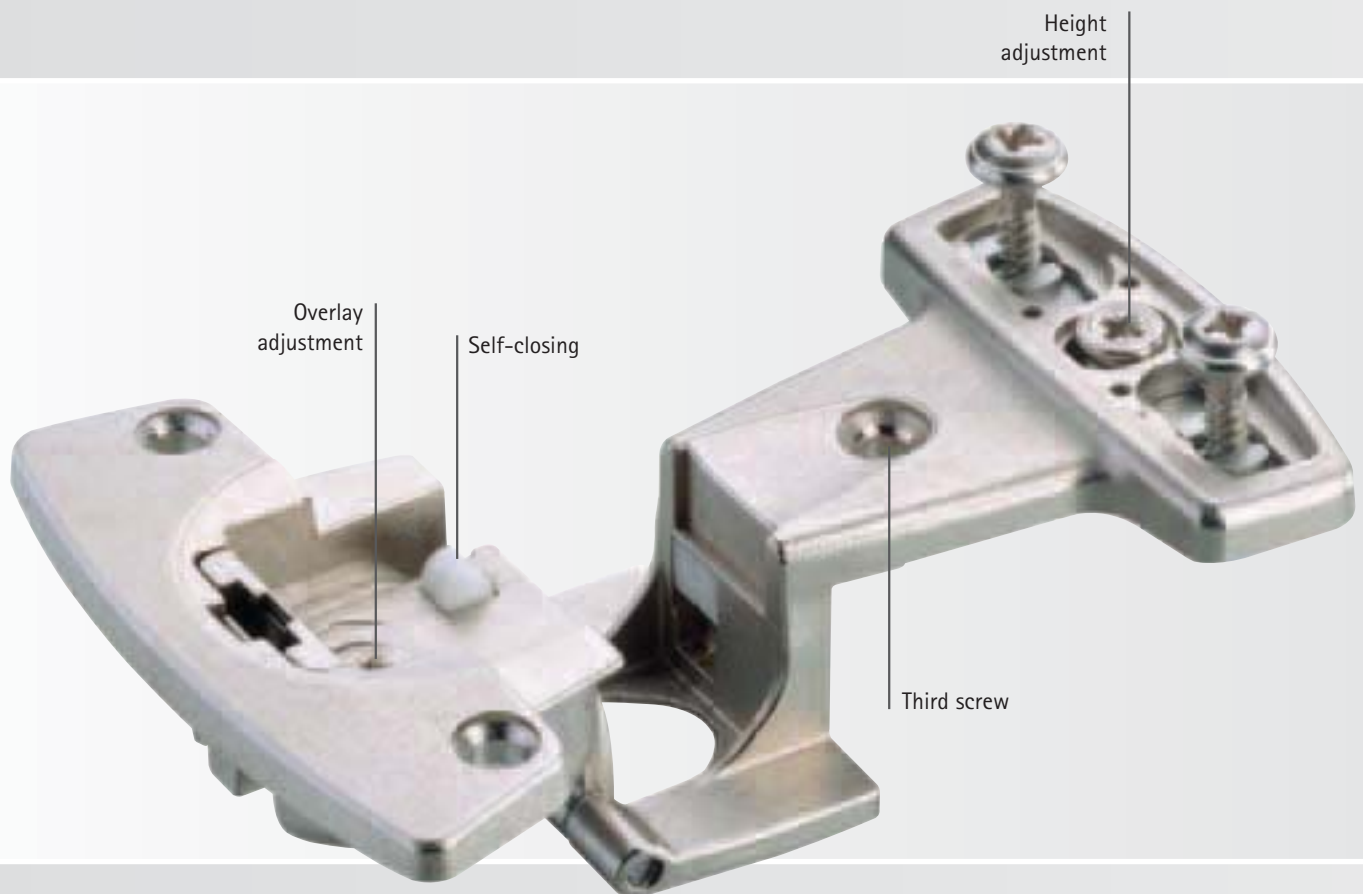

Perfect **Function**
attractive design

Fast-assembly hinge for office and commercial furniture

Light finger pressure is enough
and the hinge is securely and
quickly mounted.



Disassembly
with a screw driver

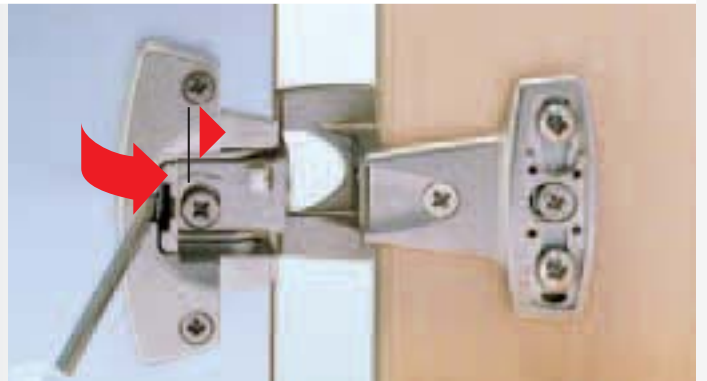

Overlay adjustment
with eccentric screw (-2 mm)

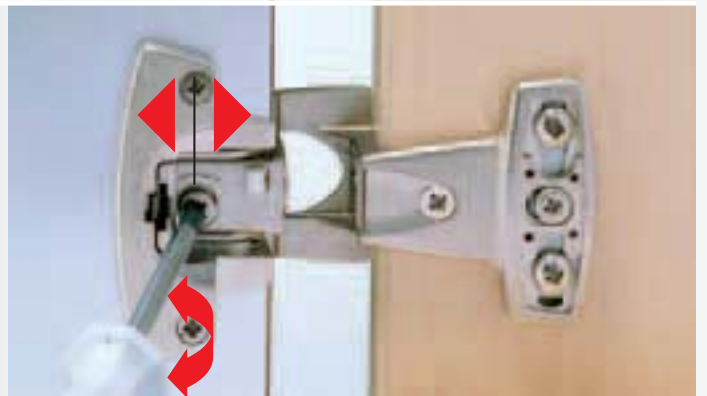

Height adjustment
with eccentric screw (± 2 mm)



Selekta Pro 2000

Single pivot hinge with snap-on assembly

For single cabinets, 19 mm sides/doors

Opening angle 270°, hole line 32 mm

For hole line 32 mm,
spacing 37 mm

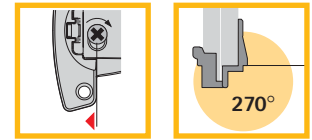

Single pivot hinge with visible knuckle, for cabinet construction and 19 mm sides/doors, precision die-cast zinc

Opening angle 270°, cup diameter 35 mm, door overlay 15 mm. Knuckle diameter 5,4 mm, knuckle length 39 mm.

Separate mounting of cup and hinge arm.

Hinge arm with **pre-mounted pan-head screws**.

Fast-assembly of doors via snap-on attachment, without tools.

High degree of protection against unintentional detachment: The lock can only be released with a screwdriver.

No door protrusion with 180° opening angle, free interior space for pull out elements.

Overlay adjustment via eccentric screw -2 mm.

Height adjustment + 2 mm/- 2 mm

by means of eccentric screw in hinge arm.

**System
32**

Fixing countersunk screw \varnothing 3,5 x 16 mm
for cup TB 22

Finish	Order no.	PU
nickel-plated	071 925	200

Selekta Pro 2000
hinge =
Hinge arm + cup

Hinge version

Corner hinge for
single cabinet construction

Door overlay 15 mm
Opening angle 270°



Mounting option

Knuckle flush

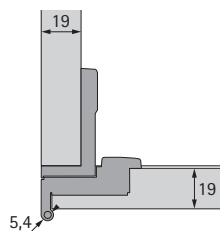

Hinge arm (order cups separately, see page 71)

Selekta Pro 2000
Die-cast zinc
with self-closing

Finish	Order no.	PU
nickel-plated	9 022 299	200

Specification

Hettich-Selekta Pro 2000 for cabinet construction and 19 mm sides/doors

Single pivot hinge with snap-on assembly

Overlay and height adjustment via eccentric screw

Hinge arm with pre-mounted pan-head screws

Hole line 32 mm, opening angle 270°, precision die-cast zinc

Cup TB 22

Screw-on
Die-cast zinc

Finish	Order no.	PU
nickel-plated	1 083 439	200

TB 22 hole dimensions

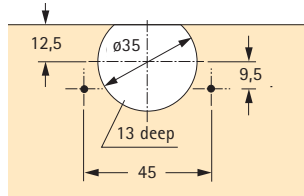
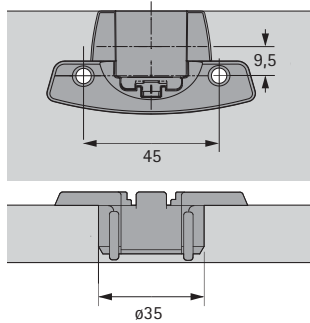

Cup TB 23

Press-in
Die-cast zinc

Finish	Order no.	PU
nickel-plated	1 080 575	200

TB 23 hole dimensions

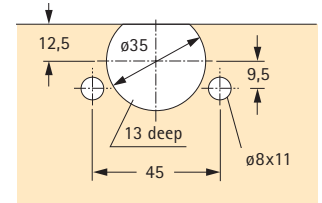
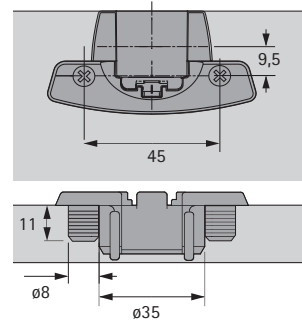

Mounting example

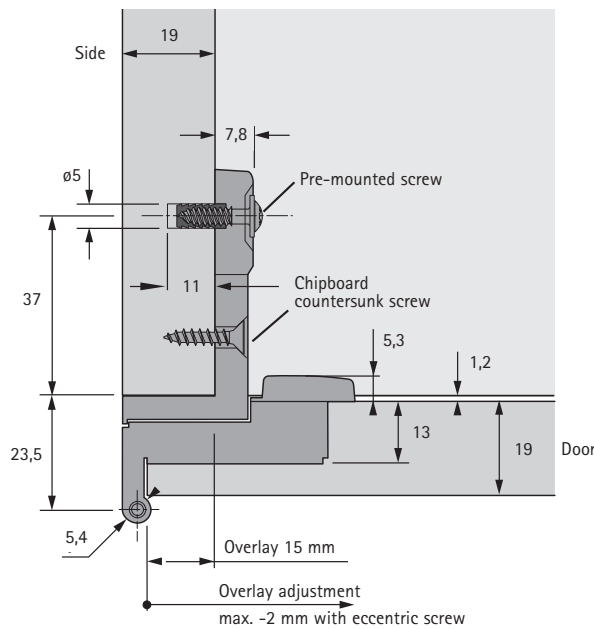

Door adjustment

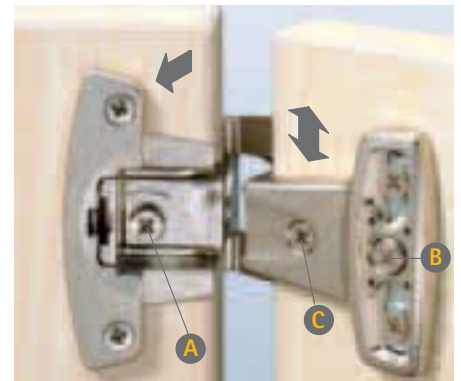

Overlay adjustment

Turn eccentric screw (A) to right, the overlay can be reduced max. -2 mm.

Eccentric height adjustment (± 2 mm)

Turn eccentric screw (B) to right or left to lower or raise the door height.

Then screw in the chipboard countersunk screws (C) $\varnothing 4 \times 16$ mm, order no. 010085, PU 200 pcs.

Accessories

Cover cap for
Selekta Pro 2000



Finish	Order no.	PU
silver-grey plastic	010067	50

Insertion dies
for drilling machine

Hole dimension	Order no.	PU
TB 23	010080	1

Hinge arm fixing screw
 $\varnothing 6,3 \times 14$ mm
for hole diameter 5 mm



Finish	Order no.	PU
nickel-plated	9021314	500

Selekta Pro 2000

Single-pivot hinge with snap-on assembly for storage wall and single cabinet construction, 19 mm sides/doors

Opening angle 180°/230°, hole line 32 mm

For hole line 32 mm,
spacing 37 mm

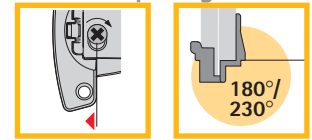

Single pivot hinge with visible knuckle, for storage wall and single cabinet construction, with 19 mm sides/door, precision die-cast zinc
Opening angle 180°/230°, cup diameter 35 mm, door overlay 11 or 5,5 mm. Knuckle diameter 7,0 mm, knuckle length 39 mm.

Separate mounting of cup and hinge arm.

Hinge arm with **pre-mounted pan-head screws**.

Fast-assembly of doors via snap-on attachment, without tools.

High degree of protection against unintentional detachment: The lock can only be released with a screwdriver.

No door protrusion at an opening angle of 180° or greater, leaving interior free for drawers.

Overlay adjustment via eccentric screw -2 mm.

Height adjustment + 2 mm/- 2 mm

by means of eccentric screw in hinge arm.

**System
32**

Fixing countersunk screw \varnothing 3,5 x 16 mm
for cup TB 22

Finish	Order no.	PU
nickel-plated	071 925	200

Selekta Pro 2000
hinge =
Hinge arm + cup

Hinge version

Corner hinge for single cabinet construction
Door overlay 11 mm
Opening angle 230°



Mounting option

Knuckle flush

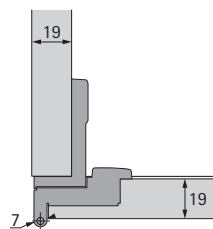

Hinge arm (order cups separately, see page 73)

Selekta Pro 2000
Die-cast zinc
with self-closing

Finish	Order no.	PU
nickel-plated	9 037 906	200

Specification

Hettich-Selekta Pro 2000 for storage wall and single cabinet construction with 19 mm sides/doors

Single pivot hinge with snap-on assembly

Overlay and height adjustment via eccentric screw

Hinge arm with pre-mounted pan-head screws

Hole line 32 mm, opening angle 180°/230°, precision die-cast zinc

Cup TB 22

Screw-on
Die-cast zinc

Finish	Order no.	PU
nickel-plated	1 083 439	200

TB 22 hole dimensions

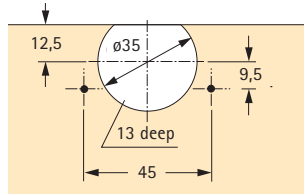
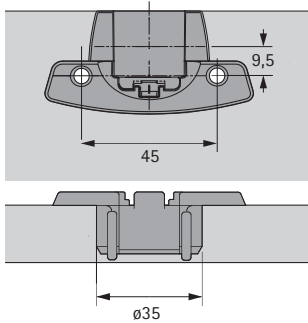

Cup TB 23

Press-in
Die-cast zinc

Finish	Order no.	PU
nickel-plated	1 080 575	200

TB 23 hole dimensions

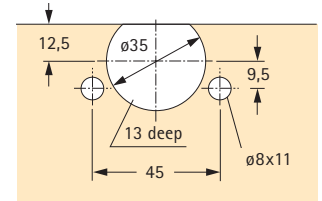
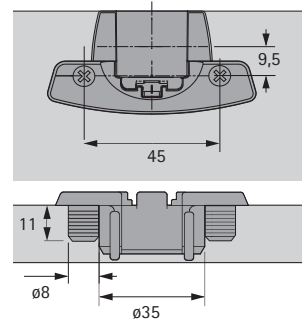

Mounting example

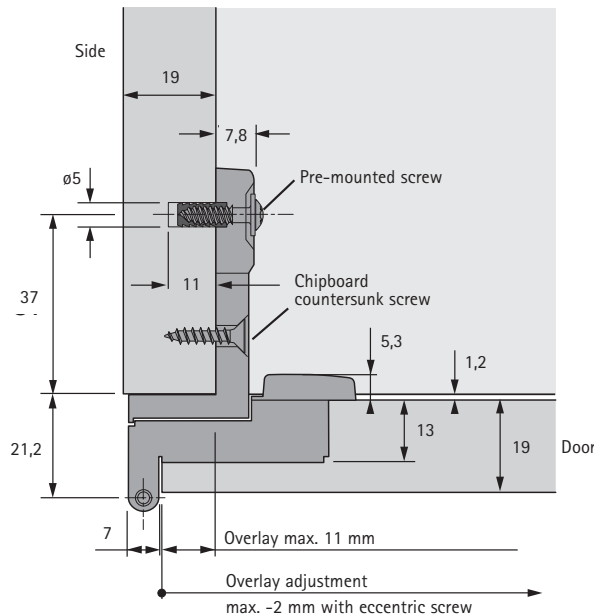

Door adjustment

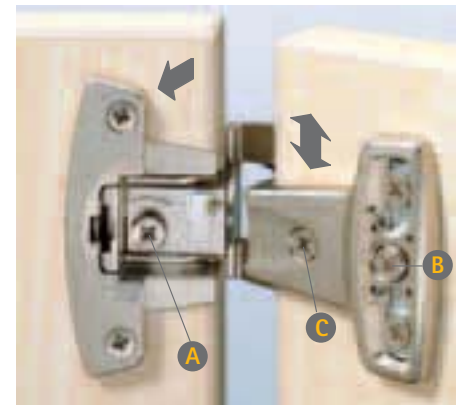

Overlay adjustment

Turn **eccentric screw (A)** to right, the overlay can be reduced max. -2 mm.

Eccentric height adjustment (± 2 mm)

Turn eccentric screw (B) to right or left to lower or raise the door height.

Then screw in the **chipboard countersunk screws (C)** $\varnothing 4 \times 16$ mm, order no. 010 085, PU 200 pcs.

Accessories

Cover cap for
Selekta Pro 2000



Finish	Order no.	PU
silver-grey plastic	010 067	50

Insertion dies
for drilling machine

Hole dimension	Order no.	PU
TB 23	010 080	1

Hinge arm fixing screw
 $\varnothing 6,3 \times 14$ mm
for hole diameter 5 mm



Finish	Order no.	PU
nickel-plated	9 021 314	500

Selekta Pro 2000 E

Single-pivot hinge with snap-on assembly for inset doors single cabinets

19 mm sides/doors, opening angle 180°

For hole line 32 mm

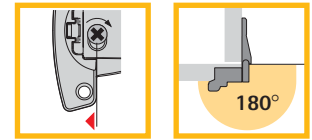

Single pivot hinge with visible knuckle for inset doors, for cabinet construction and 19 mm sides/doors, hole line 32 mm
Precision zinc diecast

Opening angle 180°, cup diameter 35 mm.
Knuckle diameter 5,4 mm, knuckle length 39 mm.
Separate mounting of cup and hinge arm.

Hinge arm with **pre-mounted pan-head screws**.

Fast-assembly of doors via snap-on attachment, without tools.
High degree of protection against unintentional detachment: The lock can only be released with a screwdriver.

No door protrusion with 180° opening angle, free interior space for pull out elements.

Reveal adjustment via eccentric screw -2 mm.
Height adjustment + 2 mm/- 2 mm
by means of eccentric screw in hinge arm.



Fixing countersunk screw \varnothing 3,5 x 16 mm for cup TB 22

Finish	Order no.	PU
nickel-plated	071 925	200

Selekta Pro 2000 E hinge = Hinge arm + cup

Hinge version

Corner hinge for single cabinet construction
Opening angle 180°



Mounting option

Inset

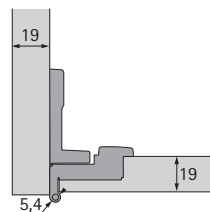

Hinge arm (order cups separately, see page 75)

Selekta Pro 2000
Die-cast zinc
with self-closing

Finish	Order no.	PU
nickel-plated	9 037 251	200

Specification

Hettich-Selekta Pro 2000 E for inset doors, cabinet construction with 19 mm sides/doors

Single pivot hinge with snap-on assembly

Side and height adjustment by means of eccentric screw

Hinge arm with pre-mounted pan-head screws

Hole line 32 mm, opening angle 180°, precision die-cast zinc

Cup TB 22

Screw-on
Die-cast zinc

Finish	Order no.	PU
nickel-plated	1 083 439	200

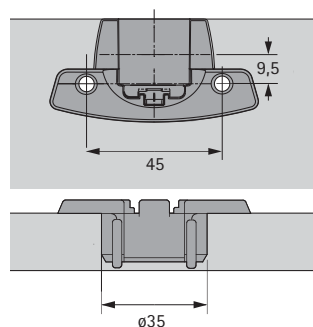

TB 22 hole dimensions

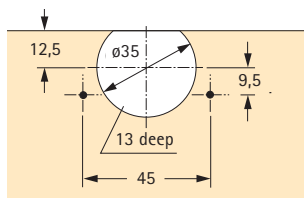

Cup TB 23

Press-in
Die-cast zinc

Finish	Order no.	PU
nickel-plated	1 080 575	200

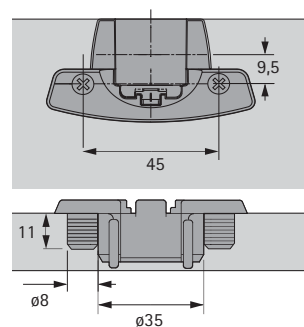

TB 23 hole dimensions

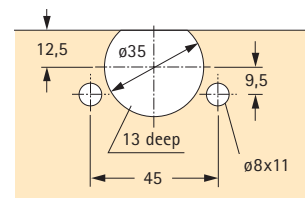

Mounting example

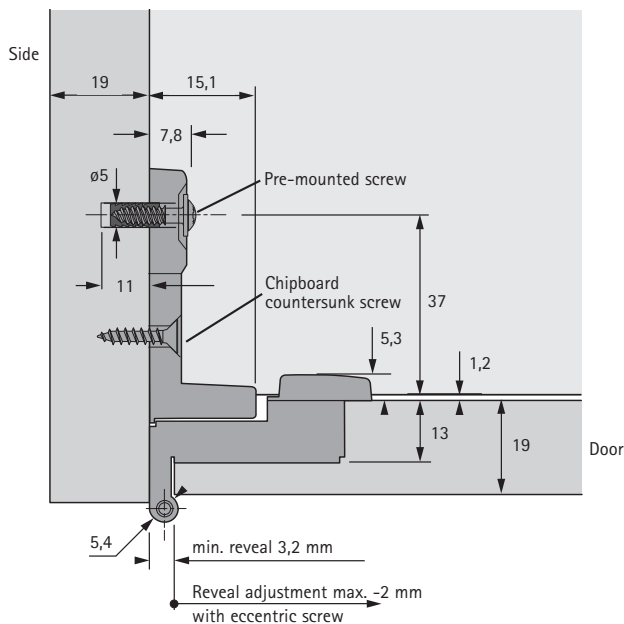

Door adjustment



Reveal adjustment

Turn eccentric screw (A) to right, to adjust the reveal by max. 2 mm.

Eccentric height adjustment (± 2 mm)

Turn eccentric screw (B) to right or left to lower or raise the door height. Then screw in the **chipboard countersunk screws (C)** $\varnothing 4 \times 16$ mm, order no. 010 085, PU 200 pcs.

Accessories

Cover cap for
Selekta Pro 2000



Finish	Order no.	PU
silver-grey plastic	010 067	50

Insertion dies
for drilling machine

Hole dimension	Order no.	PU
TB 23	010 080	1

Hinge arm fixing screw
 $\varnothing 6,3 \times 14$ mm
for hole diameter 5 mm



Finish	Order no.	PU
nickel-plated	9 021 314	500